

TENDER Weight Indicator and Controller with eight Programmable Output

Model WI608

Specifications

| | |
|-----------------------|-----------------------|
| Operating Voltage | 230VAC,50Hz |
| Power Consumption | Approx. 3VA |
| Operating Temperature | -20° C ~ 60° C |
| Load Cell Excitation | DC 5V , 120mA |
| Relay Outputs | 5 A, <250 VAC |
| Digital Inputs (AC) | 220 VAC |
| A/D Sampling speed | 50 times/sec |
| Display | 5 Digit LED 7-segment |
| Analog Input range | ±20mV |
| Input impedance | 10MΩ |
| Size | 96 X 96 X 72 mm |

Pin Configuration

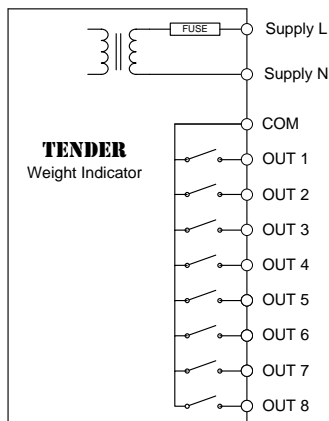
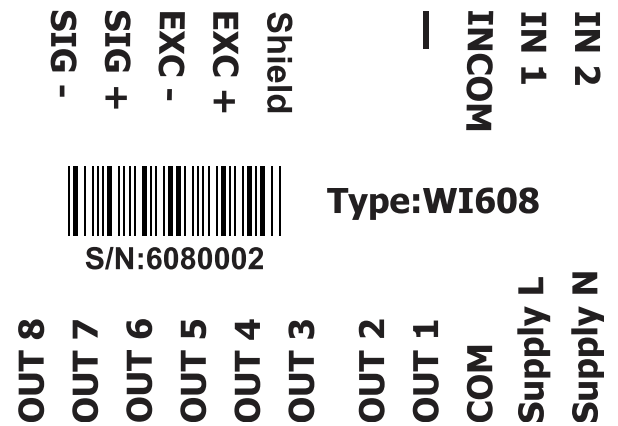

Supply and relay connection

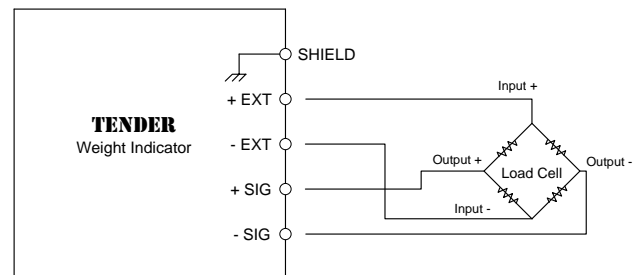

Load cells connection

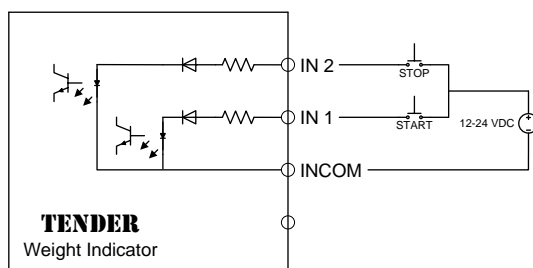

DC digital input connection

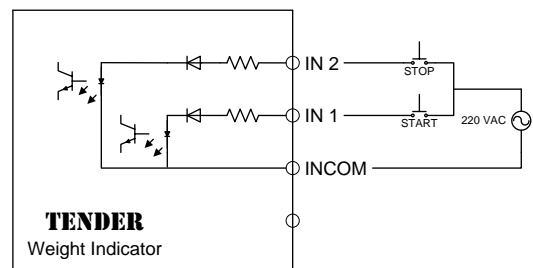

AC digital input connection

1) Load cell error messages

- **n.CELL** : It indicates disconnection or displacement of load cell wires or load cell failure.
- **S.CELL** : It indicates short circuit of load cell wires.

2) Function modes of device relays output (**FUnCt** menu):

The digital input IN1 starts the loading and outputs will be activated automatically, and each of them performs the loading up to the set point value. The number of required outputs for automatic loading can be set from one to eight via **FUnCt** menu and the other outputs will be inactive. IN2 digital input stops or inactivates outputs.

3) Final tuning system for reducing “load in air” error

This device is equipped with a system that can reduce significantly the “load in air” error by cutting and connecting continuously (pulse generation) in the output and reducing the infusion rate, until achieving the set point value.

4) Reset factory

Hold  for 12 seconds to display **FcRSt** (blinker), then press  .

5) Main setting menu of the device

In order to enter this section, hold the key  while the device is off, and turn it on.

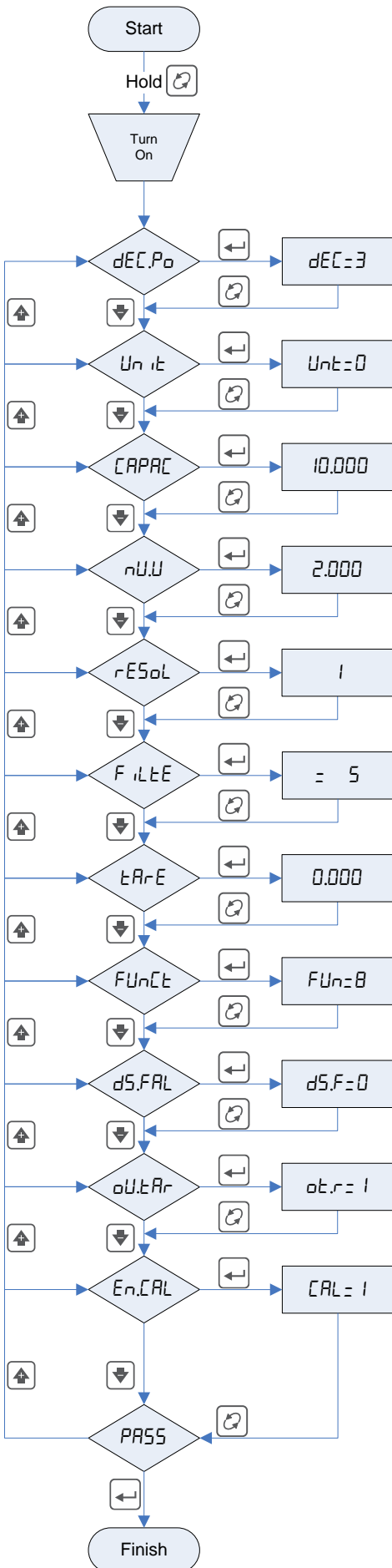

Enter the desired float number.

If the weight unit is considered to be kilogram, enter **0** and if it is for tones, enter **1**.

Enter the maximum capacity of load cells.

Enter the MV/V value or load cells sensitivity.

Select the resolution value from **1, 2, 5 ...** and **100**.

Enter the filter value or updating time per second from **5** to **50**.

Enter the tare value or dead weight, if required.

Select the device mode from **0** to **8**, considering the aforementioned explanations.



In order to display the “load in air” or infusion menu, enter **1** and to hide it, enter **0**.

For activation of automatic resetting at the loading initiation, enter **1**.

In order to activate the manual calibration, enter **1** and to inactivate it, enter **0**

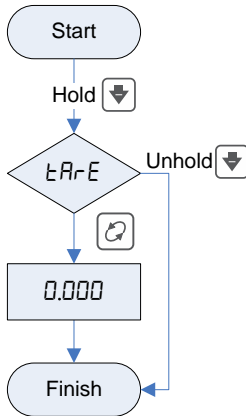
6) Manual Tare



Hold , the term **TARE** is displayed, while holding the key
 Push . The display will show zero.

7) Manual calibration

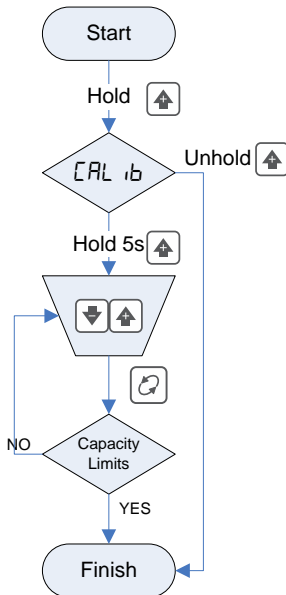

If the indicated weight is not equal to the real load value, it can be calibrated manually as following. It is obvious that after performing the manual calibration, the Capacity parameter value (in the main setting section) will change automatically.

After tare, put the weight with the determined value on the balance, and start the calibration.







Hold  for 5 seconds.

The display starts to blink.

By using  and , enter the desired weight and push 

If the calculated new load cell capacity is not in the admissible range, the system will return to the previous step and will not quit the blinking state.

8) Formula selection

Push  and hold it. The term **Prog=** is displayed, while holding . By using  and , select the desired formula.

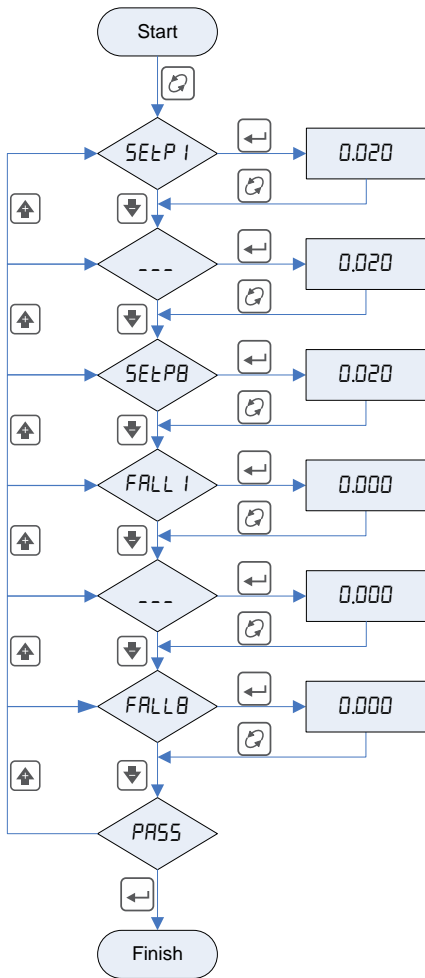

9) Set point tuning

In order to enter the menu while the device is on, push 

Enter the desired final weight in order to load from the first relay.

Repeat these actions for the other seven outputs.

- If d5.F=0 , then redirects to PASS and the FALL menus will not be displayed.

Enter the leakage value after the stop command for the first output.

Repeat these actions for the other seven outputs.

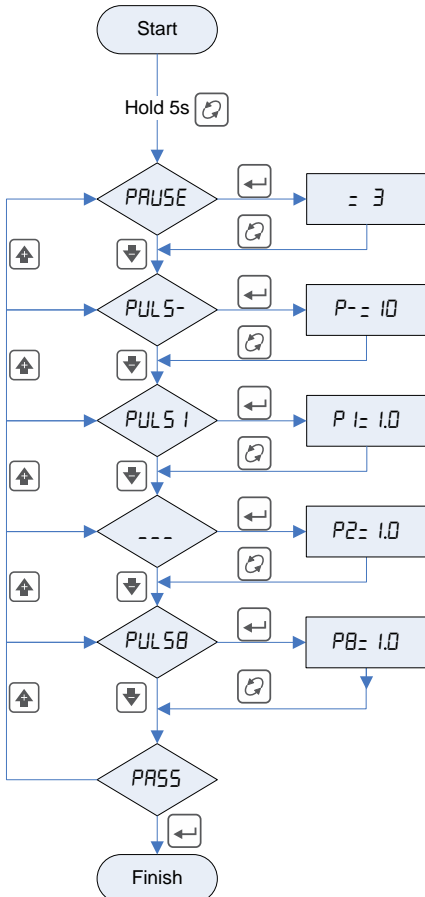

10) Accessory setting

In order to enter the menu hold  for 5 seconds.

Enter the required delay time between loadings.

Enter the maximum admissible pulse number in order to perform the final tuning.

Enter the pulse width time of the first output in the final tuning mode.

Repeat these actions for the other seven outputs.